

1083 Cast Iron Non Return Valve PN - 1.0 (Flanged)

Salient Features

- Design Standard IS 5312 - 1.
- Flanged Ends to IS 1538.
- Seating design - Swing Type.
- Bolted Cover.
- Renewable Seat with Premium Quality Rubber Flap.
- Flexible installation (Horizontal / Vertical)

PN1.0 -
Test Pressure (Hydrostatic) :
Shell : 1.5 MPa
Seat : 1.0 MPa
Maximum Working Temperature : 80°C

Suitable For
Water

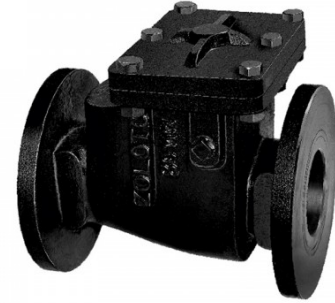

Materials

P.No.	Name of Part	Material of Material	Specification	Qty.
1	Bolts	Carbon Steel	IS 1363 Part 1 Class 4.6	To Suit
2	Cover	Cast Iron	IS 210 Gr. FG 200	1
3	Gasket	Nitrile Rubber	IS 638 Type B	1
4	Body	Cast Iron	IS 210 Gr. FG 200	1
5	Hinge Pin	Stainless Steel	ASTM A 276 Type 410	1
6	Body Seat Ring	Bronze / Stainless Steel	IS 318 Gr. LTB 2 / ASTM A 276 Type 410	1
7	Bolts	Carbon Steel	IS 1363 Part 1 Class 4.6	1
8	Washer	Carbon Steel	---	1
9	Disc Facing	Nitrile Rubber	IS 638 Type B	1
10	Disc	Cast Iron	IS 210 Gr. FG 200	1
11	Hinge	Cast Iron	IS 210 Gr. FG 200	1
12	Bolt	Carbon Steel	IS 1363 Part 1 Class 4.6	1
13	Washer	Carbon Steel	---	1
14	Plug	Carbon Steel	---	1
15	Nut	Carbon Steel	IS 1363 Part 3 Class 4.0	To Suit

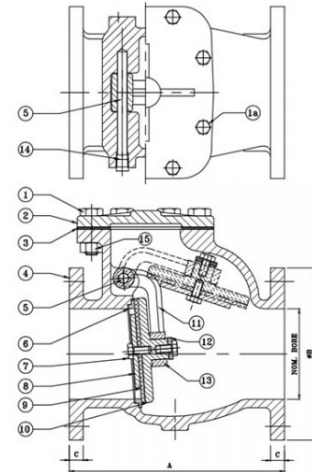

Sizes / Dimensions

Size (Inches)	Size (mm)	A	ØB	C
2	50	203 ±2	165	16 +2
2 1/2	65	216 ±2	185	16 +2
3	80	241 ±2	200	21 ±3
4	100	292 ±2	220	22 ±3
5	125	330 ±2	250	22.5 ±3
6	150	356 ±2	285	23 ±3
8	200	495 ±3	340	24.5 ±3
10	250	622 ±3	395	26 ±3
12	300	698 ±3	445	27.5 ±3